



RDL-1080RD OPERATION MANUAL



Red Dragon Laser RDL-1080RD Operation Manual

Contents

1.0 General	2
1.1 Operation Manual – General Information	2
1.2 Designated Use	2
1.3 Machine Disposal	2
1.4 Machine Specifications	2
1.5 Manufacturer Labelling	3
1.6 Machine Overview	4
2.0 Safety	5
2.1 Laser Safety Information	5
2.2 Precautions	5
2.3 Prohibited Laser Materials	6
2.4 Information and Warning Labels	7
3.0 Installation	8
3.1 Unpacking	8
3.2 Delivery Contents	8
3.3 Machine Location	8
3.4 Electrical Requirements	9
3.5 Connecting the machine to the mains	9
3.6 Connecting the water supply	9
3.7 Connecting the air pump	10
3.8 Connecting the computer	10
4.0 Operation	11
4.1 Activating and Deactivating the machine	11
4.2 Safety Controls	11
4.3 Adjusting the Z-axis	12
5.0 Maintenance	13
5.1 Cleaning the Laser Engraving Machine	13
5.2 Mirror Alignment	15
5.3 Maintenance Schedule	18
6.0 Troubleshooting	19
7.0 Wiring Diagram	21



Red Dragon Laser RDL-1080RD Operation Manual

1.0 GENERAL

1.1 Operation Manual – General Information

Caution: Prior to installation and operation, please ensure that you read and follow this operation manual carefully. Damage to the person and/or machine can result from improper use or unfamiliarity with this manual. These are the Original Instructions.

1.2 Designated Use

All RDL CO₂ Laser Engraving Machines are used for engraving and cutting a range of non-metallic materials, such as: acrylic, plywood, glass, cork, coated metals etc.

The engraving/cutting process as specified in this and any other accompanied manuals, along with any in-house training, must be adhered to.

The machine can only be operated, maintained and, if required, repaired by trained individuals who are familiar with the designated use and the potential hazards of the machine.

Non-adherence to the designated use, the safety information, or any other operational procedures may potentially cause damage to either person or machine. Any warranty will also be voided.

1.3 Machine Disposal

DO NOT dispose of this machine with domestic waste.

All electronic devices have to be disposed of according to the regional directives on electronic/electric waste disposal. For disposal queries, please contact Red Dragon Laser Ltd.

1.4 Machine Specifications

- **Model:** RDL-1080RD
- **Machine Size:** 1450*1140*980mm (Larger dimension will depend on laser power)
- **Work Area:** 1000*800mm
- **Engraving Thickness:** 0-2mm (depending on material and power)
- **Cutting Thickness:** 0-20mm (depending on material and power)
- **Engraving Speed:** 1-1024mm/s
- **Cutting Speed:** 1-300mm/s
- **Laser Power:** 80W/100W
- **Laser Type:** CO₂ sealed glass tube
- **Cooling:** Water cooling
- **Water flow protection:** Yes
- **Positioning:** Red-dot
- **Location Precision:** <=0.01mm



Red Dragon Laser RDL-1080RD Operation Manual

- **Work Platform:** Honeycomb bed
- **Lift Range:** 0-300mm, electrically adjustable
- **Power Supply:** Standard UK (Single Phase 230V, 50Hz)
- **Net Weight:** ~200kg
- **System Environment:** Windows XP/7/8/10
- **Compatible Software:** Ai/CAD plus most other design softwares will directly import to the machine software.
- **Sound Level:** 50-70 dB whilst machine is in operation.

Additional Equipment: Air assist, X-axis linear rail, water pump, air pump, rear-mounted extraction fan, laser focus stick, extraction ducting

1.5 Manufacturer Labelling

The manufacturer's label is located on the rear of the machine and will appear as this diagram below:

Laser Engraving Machine	
Model:	Controller:
Laser Power:	Weight:
Working Area:	Voltage:
Motor:	Manufacture Date:



Red Dragon Laser RDL-1080RD Operation Manual

1.6 Machine Overview



1. Machine lid
2. Viewing Screen
3. Work bed
4. Laser Head
5. Machine Controller
6. Ammeter
7. Emergency Stop
8. Laser LED
9. Key Switch
10. Legs



1. Rear Mounted Extraction Fan
2. Power Sockets
3. Air/Water Connections



Red Dragon Laser RDL-1080RD Operation Manual

2.0 SAFETY

It is vital that any operator of the machine, or anyone else interacting with it, understands all of the following safety information. Any non-adherence may result in damage to person/machine.

2.1 Laser Safety Information

- In order to assess the potential dangers that laser systems pose; they are put into 4 separate safety classes.
- The RDL-1080RD is a class 4 laser system. This means that the laser is **hazardous**, viewing of diffuse reflection is also **hazardous** and in certain circumstances there may be a **fire risk**.
- Without following safety precautions, the following risks exist as a result to exposure to laser radiation:
 - **Eyes:** Burns to the cornea.
 - **Skin:** Burns to the skin.
 - **Clothing:** Danger of fire.

2.2 Precautions

- Make sure to wear suitable safety eyewear when operating the laser.
- Make sure not to open any part of the machine, including the main lid, when the laser is operational.
- Do not put any part of your body, or any material, below the level of the bed when the Z-axis up/down function is in operation.
- CO2 fire extinguishers should be placed near the laser machine.
- Do not store any flammable materials inside the machine, and make sure to remove any material leftovers from inside the machine.
- Always maintain a free airflow around the machine, and DO NOT cover the machine during operation.
- Ensure that the machine is placed on a secure, level surface below shoulder height.
- Ensure correct manual handling procedures are followed when transporting/moving the machine.
- DO NOT disable any safety switches. This will invalidate any warranty, and can cause damage to both you and the machine.
- DO NOT leave the machine unattended when in operation.
- It is your responsibility to verify whether materials are safe to be used in the machine. It is important to consider the release of dust, fogs and gases and it is your responsibility to ensure that no maximum concentrations are exceeded (please refer to your local guidelines).
- You must fully check over the machine prior to restarting. This is especially important where the emergency stop has been used.



Red Dragon Laser RDL-1080RD Operation Manual

2.3 Prohibited Laser Materials

There are certain materials that **should not** be processed by our laser machine, as they may be harmful to your health or to the machine. These materials include:

- PVC (Polyvinyl Chloride)
- Artificial leather containing Cr IV
- Moleskin Notebooks
- Polycarbonate/Lexan
- ABS
- HDPE
- Polystyrene foam
- Polypropylene foam
- Fibreglass
- Coated Carbon Fibre
- Printed Circuit Boards (Fr4, G10)
- PVB (Polyvinyl Butyral)
- PTFE/Teflon
- Beryllium Oxide
- Any materials containing halogens, epoxy or phenolic resins

Please remember that this is **not** an exhaustive list of prohibited materials and it is important that you always ensure that your selected material can be safely processed by the laser.

If you need any further assistance, or do not understand any of this information, please contact us via www.reddragonlaser.co.uk



Red Dragon Laser RDL-1080RD Operation Manual

2.4 Information and Warning Labels

Information and warning labels are attached to the machine. Please ensure you are aware of these labels. If any labels become lost/damaged then they must be replaced immediately.





Red Dragon Laser RDL-1080RD Operation Manual

3.0 Installation

3.1 Unpacking

In most situations, your Laser Engraving Machine will be professionally installed by trained technicians from Red Dragon Laser Ltd. In certain situations this isn't possible, and the following steps apply:

- Use an 8mm hex socket, or Phillips head screwdriver (where applicable) to carefully unscrew each panel of the packing crate, starting with the lid.
- Remove the protective sheets of polystyrene from the top and sides of the machine.
- Open the lid of the machine and retrieve the components box. You will also need to remove the foam protector from the laser head gantry.
- Lift the laser machine to attach the stand. The machine is very heavy and it is recommended that you use at least 2-3 persons, or ideally a forklift or sturdy pallet truck.

It is recommended that you keep the packaging if possible, in case it needs to be re-used. Any disposal of packaging waste must adhere to the applicable waste disposal law.

3.2 Delivery Contents

- Laser Engraving Machine including the required laser optics.
- Machine Stand.
- Components Box, including:
 1. USB stick containing machine information and RDWorks Software
 2. Mains power cable
 3. Mirror/Lens cleaning kit
 4. USB connection cable
 5. Ethernet connection cable
 6. Focus tool
 7. Panel keys and tool set
 8. Stand assembly screws
 9. Extraction ducting
 10. Air assist pump
 11. Water pump

3.3 Machine Location

Before operating the Laser Engraving Machine, it is important that it is set-up in a suitable location. Some guidelines are below:

- The machine should be located on a secure, flat surface.
- Avoid placing the machine in any location where it can be exposed to mechanical shocks, high or low temperatures, high humidity or dust. The machine should not be kept in a location where the temperature regularly falls below 0°C or rises above 35°C, likewise it should not be located where the humidity exceeds 70%.



Red Dragon Laser RDL-1080RD Operation Manual

- Avoid locations with poor air circulation and select a location with easy access to ventilation.
- Ideally the machine will not be located more than 2m from the connected computer. There will also need to be 30cm available behind, and on either side, of the machine.

3.4 Electrical Requirements

It is your responsibility to provide a suitable electrical supply to the machine. Any damage caused by an inappropriate or inadequate power supply are not covered under your warranty.

Ensure that your electrical outlet is correct for the Laser Engraving Machine. The machine works off of a standard UK power outlet (Single-Phase 230V, 50Hz).

Your computer must be connected to a separate mains power socket from the Laser Engraving Machine. However, it is recommended that the computer and the Laser Engraving Machine are connected to the same circuit to prevent electromagnetic interactions.

It is important that the machine is not used during thunderstorms, or at other times when there are fluctuations in electrical power.

3.5 Connecting the machine to the mains

Please Note: Ensure that you do not turn the machine on until the water supply is connected.

All Red Dragon Laser engraving machines use a standard UK plug and simply connect to the mains supply via a power cable.

3.6 Connecting the water supply

If you are using one of the optional chillers, please refer to the manual associated with the chiller.

Firstly, retrieve the water pump from the components box and assemble (assembly instructions can be found with the water pump).

Place the water pump in a container of at least 25L, and fill up with at least 12L of de-ionised water (it is imperative that the water level is fully above the pump). Finally, you will need to connect the water inlet and outlet from the rear of the machine to the water pump.

Please Note: In Winter/cold periods it is vital that all water drains fully out of the machine and that you DO NOT use the machine if there is any ice in the water. It is fine to add a small amount of suitable antifreeze as a preventable measure (Check with the antifreeze supplier whether it is safe for laser use).

Please Note: It is important that the water is kept free of debris and replaced at least every 6-12 months. If you notice a build-up of white, stringy algae then it is fine to add a drop of non-additive bleach to the water.



Red Dragon Laser RDL-1080RD Operation Manual

3.7 Connecting the air pump

Firstly, retrieve the air pump from the components box and assemble (assembly instructions can be found with the air pump). Place the air pump in a dry area where it has clear access to airflow and is away from water. Once this is done you will need to connect the air pump to the machine via the air inlet on the rear.

3.8 Connecting the computer

The computer must be connected to the mains power and switched OFF while being connected to the laser.

The computer is physically connected via a standard USB A to USB A cable (supplied) to the port marked PC-USB (see below). The port below this marked UDISK is used when uploading a file via a memory stick. The final port is a RJ45 ethernet port to allow the laser to connect to a local area network.





Red Dragon Laser RDL-1080RD Operation Manual

4.0 Operation

4.1 Activating and Deactivating the machine

(Please refer to the diagram below for switch locations)

Once the machine is plugged in at the mains supply, it can then be activated and de-activated using a single button – the **'Main Switch'**.

Once the machine is turned on using the Main Switch, you will have to use the key to turn the **'Key Switch'** on to use the laser. When the Key Switch is on, the **'laser ON'** LED will glow white. Once you are at this stage, both the machine and the laser will function fully.

In an emergency, the machine can be immediately de-activated using the **'Emergency Stop'**. It is vital that you fully check over the machine prior to restarting, after this has been used.

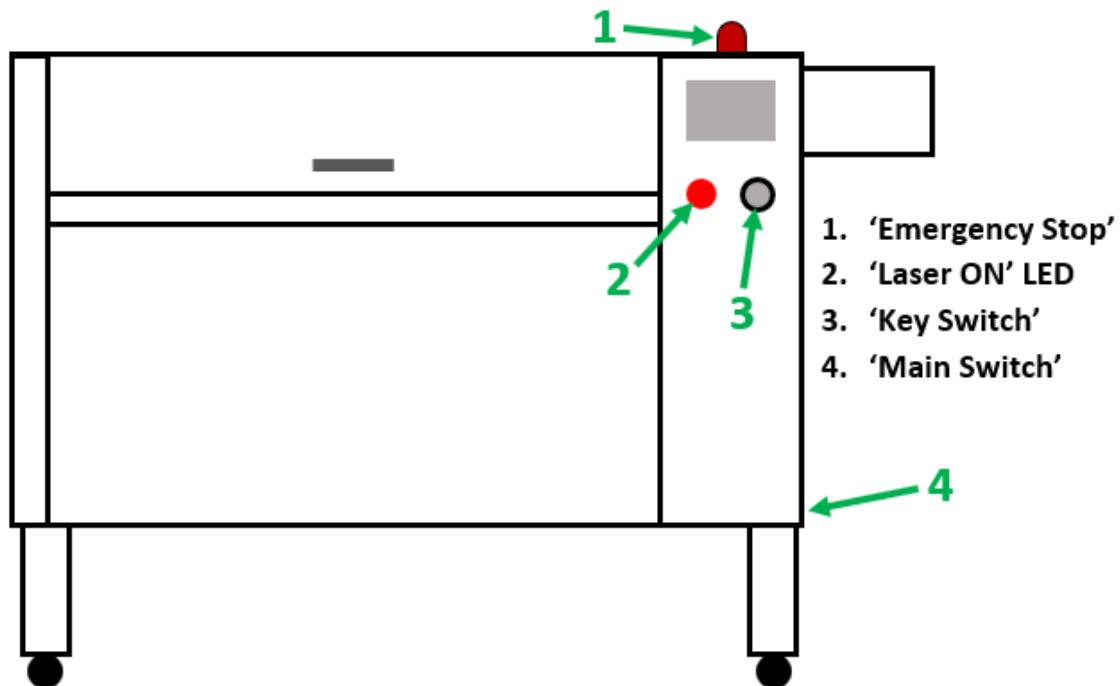

4.2 Safety Controls

There are a number of features present on the Laser Engraving Machine that will act to prevent any potential damage to the machine/person

- All machine panels, with the exception of the lid, use key locks so that they cannot be entered accidentally while the laser is running.
- The lid and the laser tube enclosure utilise proximity interlock switches. These immediately switch off the laser if the lid or tube enclosure are opened during operation.
- A flowmeter is connected to the water system. If no flow of water is detected, then the laser will immediately shutoff to prevent any damage to the laser tube.



Red Dragon Laser RDL-1080RD Operation Manual

4.3 Adjusting the Z-axis

The z-axis represents the vertical axis of the machine workspace. The workspace can be moved up and down using these 2 buttons on the right-hand side of your machine:



The lower rocker switch will allow these buttons to be operated. The machine workspace cannot move while this rocker switch is in the OFF position.

For detailed operating instructions regarding the machine keypad and controller, please refer to the 'RuiDa Controller User Manual – 6442-S'.

For detailed operating instructions regarding the RDWorks software, please refer to the 'RDWorks Software User Manual'



Red Dragon Laser RDL-1080RD Operation Manual

5.0 Maintenance

Prior to undertaking any maintenance on the Laser Engraving Machine, you must ensure that the machine is turned off and disconnected from the mains power supply.

5.1 Cleaning the Laser Engraving Machine

It is important to regularly clean both the machine and the laser optics to ensure that your Laser Engraving Machine runs efficiently. Ensuring that any cutting debris is cleaned out of the bottom of the machine is vital in preventing material fires within the machine.

General Machine Cleaning

You must check, at least once daily, whether dust or cut material has accumulated at the bottom of the machine underneath the workspace. By ensuring that your machine is clean you will increase efficiency, as well as reducing servicing costs and fire risk.

1. Ensure the Laser Engraving Machine is turned off and is disconnected from the mains power supply.
2. Open the main lid of the machine and carefully remove the bed from the workspace. The bed can be cleaned using warm water and a general degreaser or window cleaning agent – ensure it is left to dry thoroughly.
3. Remove any debris from the bottom of the machine. Once this is clear, use the keys from the components box to unlock each side panel so that these interiors can be thoroughly cleaned as well.
4. If necessary, clean the viewing screen on the lid with a microfibre cloth (abrasive materials such as paper towels are likely to scratch the screen).



Red Dragon Laser RDL-1080RD Operation Manual

Cleaning the Lens

The lens is extremely fragile and must be handled carefully, it is important to hold it on the edges so as not to smudge the main surface.

1. Lower your workspace so that there is at least 10cm of space available underneath the bottom of the laser head.
2. Disconnect the air assist pipe and unscrew the laser nozzle from the rest of the laser head using the fixing ring, the lens will be sitting inside:



3. The lens can be delicately removed after using a pin spanner to remove the top seal. It is important that you note the orientation of the lens as you remove it, as it will need to be replaced in the same way.
4. Use air to gently blow away any surface dust/debris off of the lens.
5. Retrieve the cleaning kit from the components box and spray some of the recommended cleaning fluid on one end of a cotton bud. Gently wipe this end over each surface of the lens in a circular motion, until any haze or discolouration is gone.
6. Use the other end of the cotton bud to gently dry each lens surface using the same motion.
Please note: DO NOT re-use cotton buds as you may transfer debris.
7. Inspect the lens and repeat the above steps if it is still dirty.
8. Gently re-insert the lens (taking care to ensure it is in the correct orientation) and tighten the top seal. **Please note:** DO NOT overtighten this seal as you may damage the lens.
9. Re-fit the nozzle to the rest of the laser head and tighten with the fixing ring. Re-connect the air assist pipe.



Red Dragon Laser RDL-1080RD Operation Manual

Cleaning the Mirrors

The mirrors in RDL Laser Engraving Machines can be cleaned in-situ. Ensure you DO NOT loosen any screws on the mirror housing, as this will put your mirrors out of alignment. There are 3 mirrors present in the Laser Engraving Machine.

1. Use air to gently blow away any surface dust/debris off of the mirror.
2. Retrieve the cleaning kit from the components box and spray some of the recommended cleaning fluid on one end of a cotton bud. Gently wipe this end over the mirror surface in a circular motion, until any haze or discolouration is gone.
3. Use the other end of the cotton bud to gently dry the mirror surface using the same motion.
Please note: DO NOT re-use cotton buds as you may transfer debris.
4. Inspect the mirror surface and repeat the above steps if it is still dirty.

5.2 Mirror Alignment

Firstly, familiarise yourself with the three adjustment screws on the mirrors. Different screws move the mirrors in different directions. Do not forget to tighten the locking nut on each screw when you have finished each step.

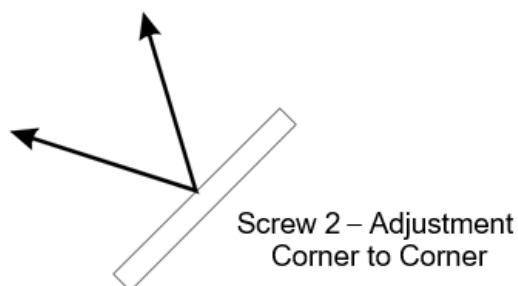
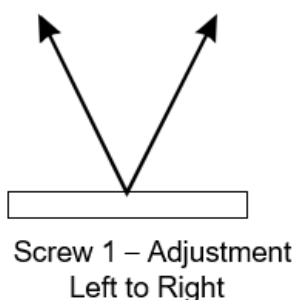
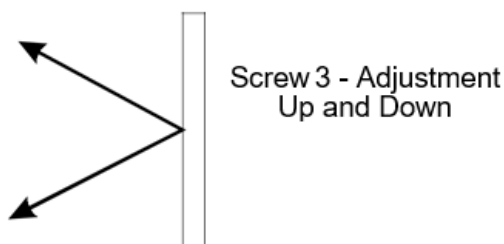
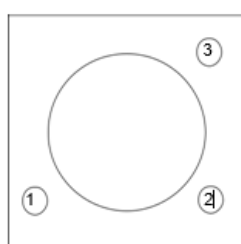

Adjust each screw slowly, carefully and ONE AT A TIME ONLY.

You must ensure that the lid of the machine is closed when pulsing/firing the laser.

Place a piece of double-sided tape in front of each mirror (not on the mirror), and you're ready to start!



Red Dragon Laser RDL-1080RD Operation Manual

Part 1 – Aligning Mirrors 1 and 2

Step 1

- Move the gantry to the front right of the machine.
- Pulse the laser and have a look at the tape on mirror 2.
- Adjust mirror 1 until the laser hits the centre of the tape on mirror 2 in the bottom left.

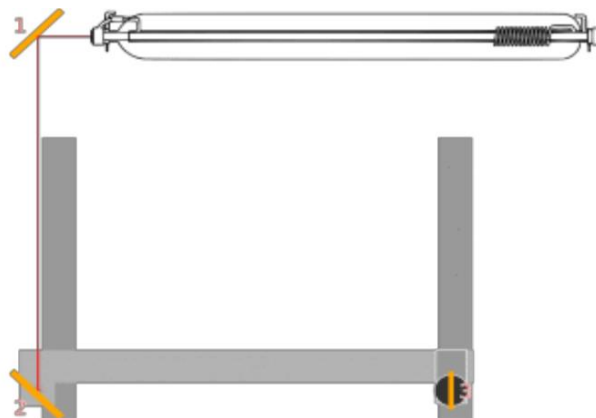

Step 2

- Move the gantry to the back right of the machine.
- Pulse the laser again and check that the burn mark is still centred on the tape. Adjust if necessary.

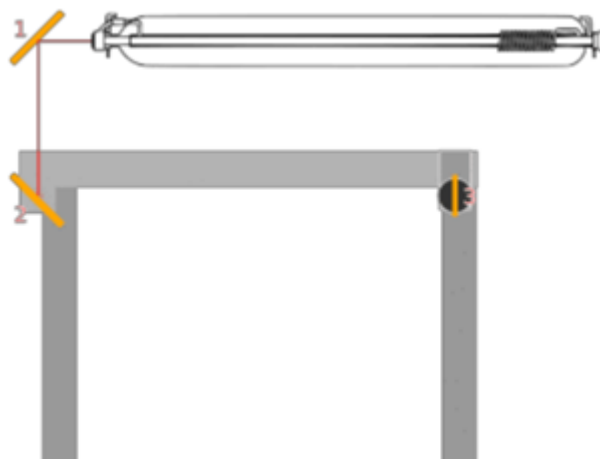



Red Dragon Laser RDL-1080RD Operation Manual

Part 2 – Mirror 3 and Laser Head

It is important that you **do not** change the mirror alignment at all from part 1.

Step 3

- Move the gantry to the front right of the machine.
- Pulse the laser and have a look at the tape on mirror 3.
- Adjust mirror 2 until you hit centre on mirror 3 (so that the laser passes through the head and out of the nozzle).

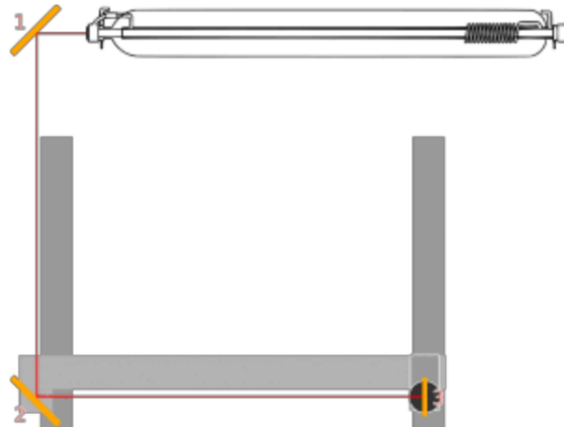

Step 4

- Move the gantry to the front left of the machine.
- Pulse the laser and check that the burn mark is still centred on the tape on mirror 3. Adjust if necessary.

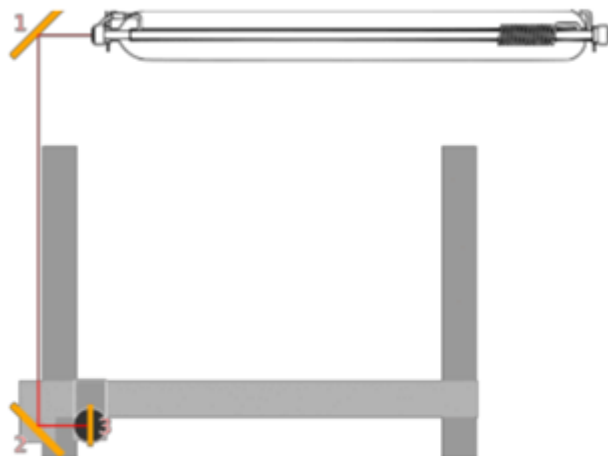



Red Dragon Laser RDL-1080RD Operation Manual

Step 5

Finally, ensure that the laser beam is coming directly out of the end of the nozzle aperture in a perfect circle. If it is hitting the edge of the laser nozzle you will not be able to cut properly. This can be adjusted with mirror 3.

5.3 Maintenance Schedule

	Daily	Weekly	Monthly	Annually
Machine Component				
<i>Lens</i>	Check, and clean if required.			
<i>Mirrors</i>	Check, and clean if required.			
<i>Honeycomb/blade bed</i>			Check, and clean if required.	
<i>Linear rails and belts</i>		Check, and clean/remove debris if required.	Lubricate rails with a PTFE dry lubricant.	
<i>Cooling Water</i>	Check for any debris/ice etc.			Replace.
<i>Extraction fan</i>			Check, and clean if required.	
<i>Water/air assist pump</i>	Check that there is a clean flow, with no blockages.			
<i>General machine workspace/compartments /lid screen</i>	Check, and clean if required.			

Please note: It is the user's responsibility to maintain the machine. This Maintenance Schedule is a guide and the exact maintenance required will depend on the amount of use.

If you need any further assistance, or do not understand any of this information, please contact us via www.reddragonlaser.co.uk



Red Dragon Laser RDL-1080RD Operation Manual

6.0 Troubleshooting

This is a simple troubleshooting guide only. If these solutions do not solve your problem then please contact Red Dragon Laser directly.

The machine does not activate

- Check that there is electricity supplied to the mains and that all switches are correctly activated on the machine.
- Check the fuse in the mains power plug, and the fuse by the mains connection socket to see if they are blown and replace if necessary (ensure the power is disconnected while performing this task).

'Machine protect' error

This error will show on the controller when attempting a task while either the machine lid or tube enclosure lid is open. Ensure both of these are closed before resuming.

'Frame slop' error

This error occurs when the workspace is not large enough for the design that you are processing:

- Ensure that your design fits correctly within the workspace.
- Ensure that your workspace is not inverted, and that your machine origin point is set to the top-right within the software.

The machine turns on and operates, but with no red light or laser

Ensure that the Key Switch is activated and the Laser LED is glowing white.

The machine turns on and operates fully, with the exception of the laser

Ensure that there is water flowing through the laser system. If no water flow is detected then the laser will not activate.

'Communication error'

Check that the USB cable connecting the computer to the machine is plugged in fully and correctly at both ends.

Thick cut lines/inability to cut through material properly

- Ensure that your laser head is correctly focussed to the material, using the Focus Tool provided in the components box.
- Ensure that all 3 mirrors are cleaned and fully aligned. Also ensure that the lens is clean.
- Measure to see if the bed has dropped slightly in one corner. This can be adjusted using allen keys.



Red Dragon Laser RDL-1080RD Operation Manual

Wavy cut/engrave lines and/or periodic freezing of the laser head

- Ensure that there is no debris/dirt caught in the belts, bearings or linear rails.
- Ensure that the belts are tightened adequately, using the thumbscrews present at the end of each belt.

Laser not cutting/engraving correctly in one area of the workspace only

- Ensure that all 3 mirrors are cleaned and fully aligned. Also ensure that the lens is clean.
- Measure to see if the bed has dropped slightly in one corner. This can be adjusted using allen keys.

'Not enough extend space' error

Ensure that your design correctly fits within your workspace.



Red Dragon Laser RDL-1080RD Operation Manual

7.0 Wiring Diagram

